

## System Engineering

20.109(F12)  
M2D2 lecture  
10.16.12

### Abstracted View of Bacterial Photography

Photons	Color
1	0
0	1

Input x	Output y
1	4
2	6

### The 2CS paradigm: in words

<b>Name</b>	Two-component system
<b>Description</b>	Two-component signal transduction systems enable bacteria to sense, respond, and adapt to changes in their environment or in their intracellular state. Each two-component system consists of a sensor protein-histidine kinase (HK) and a response regulator (RR). In the prototypical two-component pathway, the sensor HK phosphorylates its own conserved His residue in response to a signal(s) in the environment. Subsequently, the phosphoryl group of HK is transferred onto a specific Asp residue on the RR. The activated RR can then effect changes in cellular physiology, often by regulating gene expression. Two-component pathways thus often enable cells to sense and respond to stimuli by inducing changes in transcription.

**KEGG: Kyoto Encyclopedia of Genes and Genomes**

KEGG is a database resource for understanding high-level functions and utilities of the biological system, such as the cell, the organism and the ecosystem, from molecular-level information, especially large-scale molecular datasets generated by genome sequencing and other high-throughput experimental technologies (See Release notes for new and updated features).

<http://www.genome.jp/kegg/>

**BRENDA**  
The Comprehensive Enzyme Information System

<http://www.brenda-enzymes.info/index.php4>

### The 2CS paradigm: cartoon 1 (information flow)

```

graph TD
    Stimulus --> HK[Sensor protein (HK)]
    HK -- "± ⊕" --> RR[Response regulator (RR)]
    RR --> Output
  
```

### The 2CS paradigm: cartoon 2 (His, Asp)

Slide from Mike Laub

### The 2CS paradigm: cartoon 3 (reactions)

RXN 1: Autophosphorylation in response to stimuli

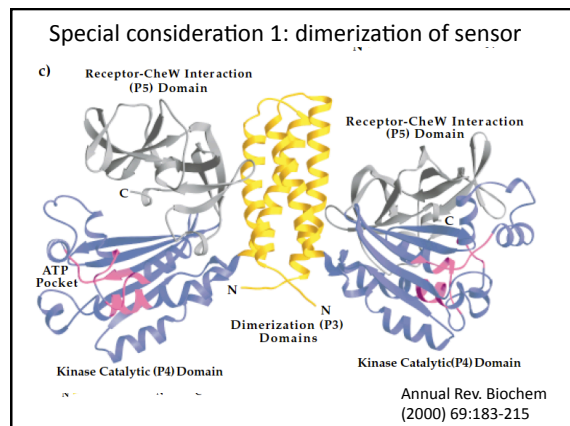
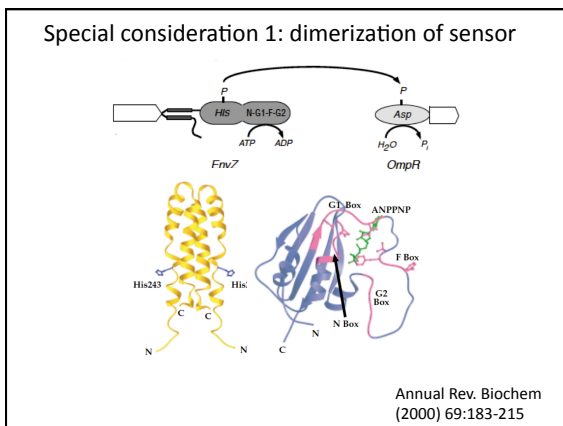
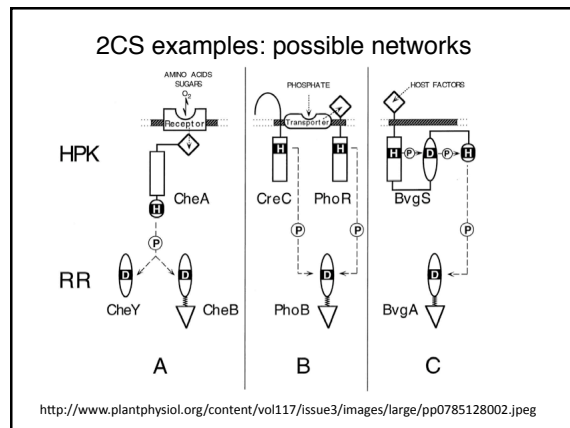
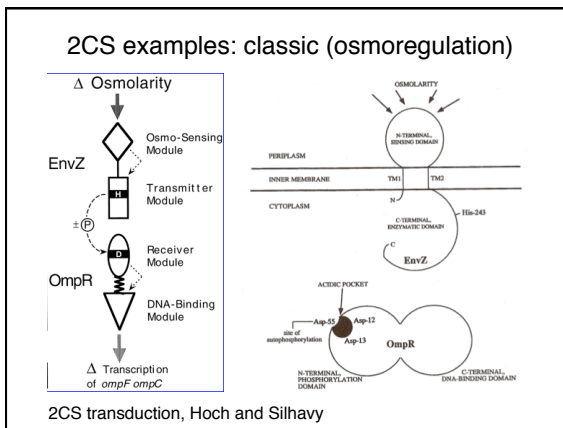
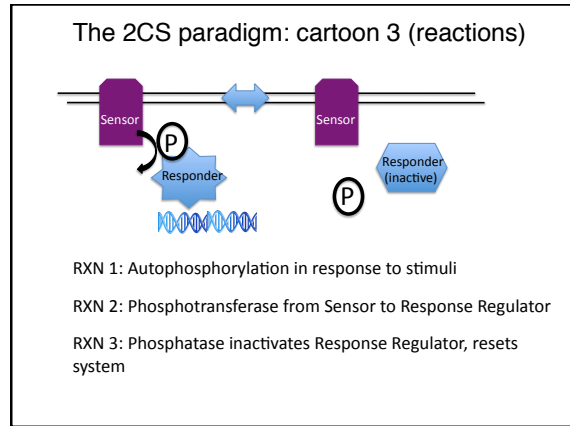
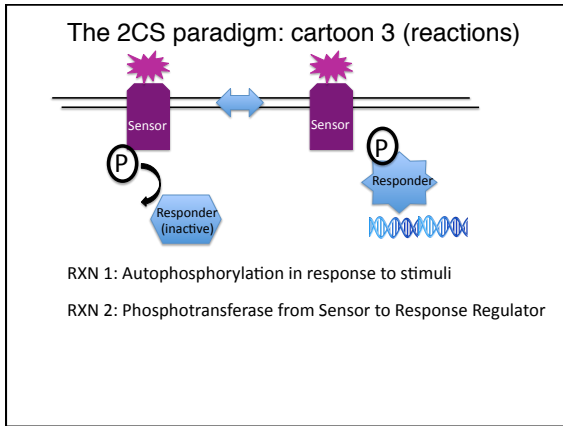

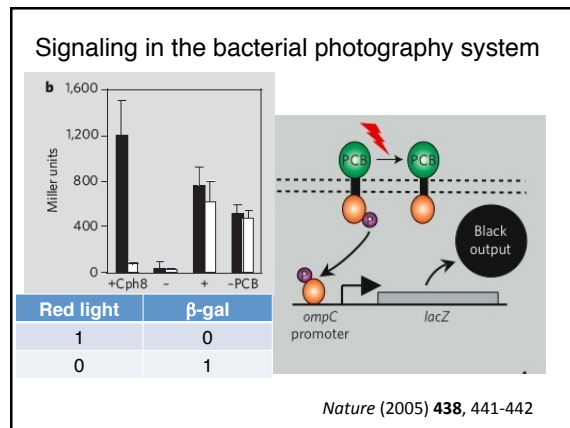
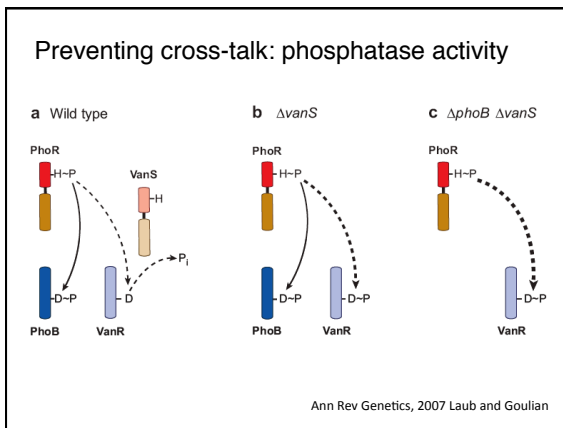
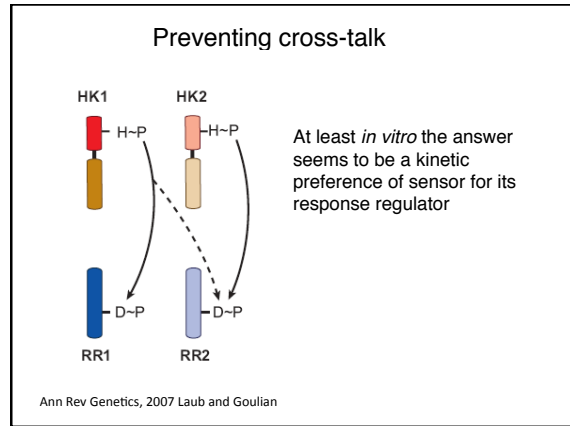
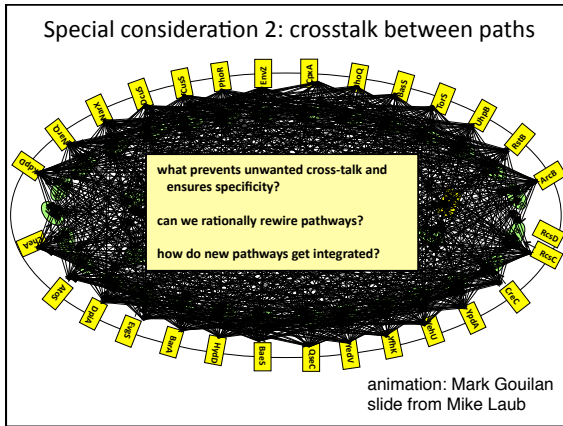

### Summary

2CS paradigm  
in words  
in cartoons

Idea Storm for Research  
Organisms game

Two other considerations  
dimerization  
crosstalk

Bacterial  
Photography

